

Garlock Butterfly Valves

Trusted throughout chemical, petrochemical and many other industries



Table of contents

GARLOCK BUTTERFLY VALVES

Overview	3
The correct type of lining	4
Head flange, body, flange types design and shaft sealing	5
Materials	6
Production	7
Test engineering	8
Standards	9
The correct material choice for your application	10

GAR-SEAL, SAFETY-SEAL, MOBILE-SEAL

Applications	
GAR-SEAL	11
SAFETY-SEAL	12
MOBILE-SEAL	13
Materials	14
Dimensions	
Wafer	15
Lug	16
Wafer tank truck MOBILE-SEAL	17

STERILE-SEAL

Applications	18
No survival for bacteria	19
2-chamber-system guarantees production safety	20
Materials	21
Dimensions	
Wafer	22
Lug	23
Exploded view	24

HEAD FLANGE

Dimensions	25
------------	----

MANUAL OPERATORS

Hand-Lever	26
ADR-Hand-Lever	26
Gear Operator	27

TECHNICAL DETAILS

Standard Design	28
Special Vacuum Design	30
Data and Facts for Vacuum Design	31

Garlock Butterfly Valves

For corrosive and abrasive media

The economic advantages of reduced maintenance, smooth operation and exceptional service life are proven over and over again. Garlock valves set the standards in TA-Luft compliance. The reliability of Garlock butterfly valves is not only appreciated and well known at our customers but also certified with SIL 3 according to EN 61508.

GAR-SEAL

GAR-SEAL valves are used extensively where corrosive, abrasive and toxic media needs to be reliably controlled. They are typically used for accurate control, throttling and shut-off duties in the chemical, petrochemical, chlorine, paper, electro-plating and many other industries. GAR-SEAL butterfly valves offer reduced maintenance requirements and increased operational reliability.



MOBILE-SEAL

MOBILE-SEAL valves are used on road tanker vehicles, railway wagons, silos and other transportation and storage containers where high chemical resistance, reliability and special safety requirements are essential. MOBILE-SEAL is EN 14432 approved.



SAFETY-SEAL

SAFETY-SEAL valves are used in applications where corrosive, abrasive and toxic media needs to be handled and electrostatic charges must be avoided at the same time.



STERILE-SEAL

STERILE-SEAL valves are used on duties where sterile processes need to be maintained in the pharmaceutical and food industries without unnecessary and costly overhauls and replacement. The special characteristic of this valve is its external sterilization capability. The design is such that the critical „dead“ areas of the valve, as well as the disc, body liner and seals, can be sterilized with steam without coming in contact with the process medium.



The correct type of lining

Operating temperature:

-40 °C up to +200 °C

-40 °F up to +392 °F



PTFE

Void-free body liner and disc isostatically molded from virgin PTFE. High material density >2.16 g/cm³. Guaranteed lining thickness of at least 3 mm plus high crystallinity. FDA conform.

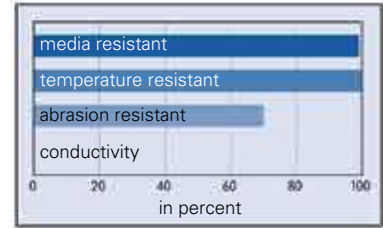

Operating temperature:

-40 °C up to +200 °C

-40 °F up to +392 °F



Abrasive PTFE

Is the chemical resistance of PTFE needed and the media also provided with abrasive characteristics, the use of PTFE anti-abrasive is recommended. This special PTFE compound is essentially resistant to mechanical wear with almost the same chemical resistance as virgin PTFE. Is the chemical resistance of PTFE

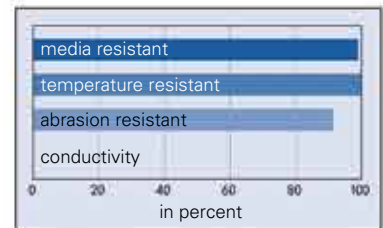

Operating temperature:

-40 °C up to +200 °C

-40 °F up to +392 °F



Antistatic PTFE

For explosive environments and medias this electrostatically conductive lining is available. The service life is comparable to the values for valves lined with PTFE. The material is FDA conform. TÜV approval (TÜV 941 F 416 601). Surface resistance ≤ 10⁶ Ω. Volume resistance ≤ 10⁶ Ω cm.

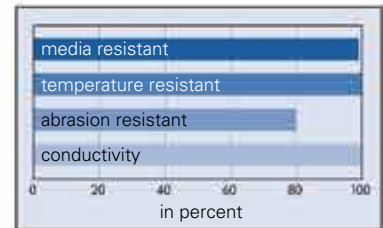

Operating temperature:

-40 °C up to + 85 °C

-40 °F up to +185 °F



UHMWPE

Used in extremely abrasive media applications while offering excellent chemical resistance. Garlock offers a complete, ultra high molecular weight PE (UHMWPE) liner and encapsulated disc.

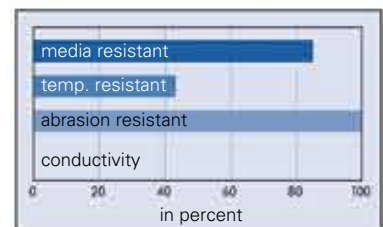

With reliability at the forefront

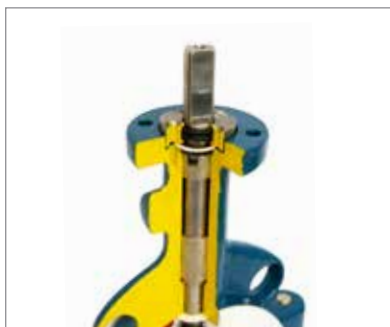

Section through the head flange

The shaft is sealed against atmospheric pollution and corrosion by two O-rings. TA-Luft compliant sealing is standard. If control connection is needed, it can be integrated to observe the shaft tightness.

Body

According to Pressure Equipment Directive the bodies of Garlock valves are approved by TÜV Rheinland according to DIN 3840 and EN 12516.

Flange types

The valves are available in Wafer, Lug and wafer tank truck type.



Design

The two piece design of shaft and disc allows an easy change of disc and liner. To your convenience disc and liner can be delivered as a pre assembled set.

Shaft sealing

The fully reliable shaft sealing system with the Garlock seal rings guarantees tightness over a long period. The shaft sealing system consists of two barriers. The first is an area where disc and liner are pressed together. The second barrier is the Garlock seal ring which includes a PTFE-ring energized by two O-rings. The long extensively approved system is completely maintenance free. The structure allows easy maintenance and replacement of disc and liner on site without special tools. The shaft sealing is certified according to „TA-Luft“ and exceeds the requirements.



Quality assurance

Garlock valves set the standard in high quality. To ensure this and guarantee a long reliable life time the Garlock quality management system is certified according to ISO 9001 and DGRL 2014/68/EU Module H1. Each valve is extensively tested according to EN 12266 before leaving our factory. To ensure absolute traceability of the materials each valve is tagged with a serial number on a stainless steel tag. Based on the serial number, material certificates for body parts, PTFE/UHMWPE resins, shaft and steel disc can be provided. This high standard guarantees absolute quality, control and transparency.

Certificates and approvals

- » DIN EN ISO 9001:2008
- » 2014/68/EU
- » Material certificate EN 10204 - 3.1
- » Testing according to EN 12266
- » 100% spark test of all PTFE and UHMWPE parts

Materials



Housing materials

It is standard practice that the housings of the Garlock valves and fittings are manufactured from high-quality ductile cast iron (EN-JS 1049). Depending on the intended use, however, other materials, such as cast steel (1.0619) and stainless steel (1.4581) are also available. All housings are manufactured and inspected in accordance with the specification of the pressure equipment directive.



Liner

Depending on the intended use, a large selection of lining materials is available. To provide reliable seals, PTFE is available in several versions as well as UHMWPE. All lining materials are manufactured by specialists and inspected comprehensively. Your contact for Garlock products will be happy to assist you in selecting the suitable material.

Elastomers

- » Silicon (standard)
- » EPDM
- » FKM
- » Neoprene



Disc

The disc is also available in different materials depending on application. Along side plastics such as PTFE and UHMWPE, stainless steel, Hastelloy C22 or Titan Grade 2 are an option. All discs are manufactured by specialists and inspected comprehensively.



Marking

Each valve is tagged with a stainless steel plate. All information such as dimension, serial number, type, materials, operating pressure and temperature, flange connection and certification are engraved.

Production



All processes have been defined through our ISO 9001 quality assurance system. The system is regularly reviewed and constantly developed. Quality, service and flexibility of the highest order are standard requirements we impose on ourselves and all our suppliers.

Approvals

- » 2014/68/EU
- » TA Luft / VDI 2440
- » EN 61508 - SIL
- » EN 14432 (MOBILE-SEAL)
- » FDA
- » EG 1935/2004
- » ISO 15848-1 AH



Due to our production facility in Germany and stock all over the world, we are in a position to react to your requirements in a very short time, worldwide.



We manufacture each valve according to customers requirements. In doing so, we carry out all necessary configurations as per your specifications.

Custom-tailored service

We are happy to help you to find the most suitable product for your particular application. In this respect, we have a high number of standard products available to you. In addition, project planning and design of custom-made solutions for our customers is one of our strengths, where we draw on decades of experience as a global manufacturer of seals and valves.

We offer professional consulting and project planning that is geared towards your requirements. Your benefit from our individual on-site support services which are specifically tailored to meet your company's needs. We conduct training seminars, help optimize inventory, reduce emissions, ensure functionality and prevent costly downtime. Our experienced employees will be happy to assist you at any time.

Test engineering

Testing

All our valves are tested according to EN 12266-1 before they are sent out to you. Standard tests are body strength (P10), body tightness (P11) and seat tightness (P12). Also a functional test is performed.



Dimensions of liner thickness

On all PTFE parts, the liner thickness is also checked in accordance with specific measuring methods. The test ensures that the required thicknesses are adhered reliably for all parts. This measure is indicative of the special attention paid to quality requirements of Garlock valves.

This guarantees a long and reliable lifetime of PTFE and UHMWPE parts during operation.



To ensure constant high quality valves all components are subjected to stringent testing running in parallel with all stages of production.



Vacuum

Garlock valves are suitable for use in a vacuum. For use in practical applications at elevated temperatures and simultaneously high vacuums there are special vacuum linings with increased wall thickness available.



Conductivity

The PTFE body lining and the lining of the disc of the SAFETY-SEAL (conductive version) are all checked for the required conductivity.

These measurements are carried out with the resistivity measurement device in accordance with the specific guidelines. This ensures that electrostatic loads are safely discharged during operations.

Standards

Garlock Butterfly Valves provide improved reliability

Face-to-face dimensions

- » DIN EN 558-1 GR 20, (DN 350 GR25)
- » ISO 5752 Table 5 short
- » ASME B16.10
(2" to 12" Table Narrow
14" to 24" Table Wide)
- » MSS-SP 67
(2" to 12" Table Narrow
14" to 24" Table Wide)
- » API 609
(2" to 12" Category A Table 2
14" to 24" Category B Table 3)

Head flange

- » EN ISO 5211
- » NF E 29-402

Body types

- » Wafer
- » Lug
- » Tank truck
- » With long neck for insulation in accordance with HeizAnl.V (German Heating Installations Ordinance)

Body strength

- » DIN EN 12516 T2 (DIN 3840), tested within the scope certification according to 2014/68/EU Module H1

Body materials

- » Spheroidal graphite cast iron (EN-JS1049, 0.7043)
- » Cast steel (GS-C 25, 1.0619)
- » Stainless steel casting (G-X5CrNiMoNb 18 10, 1.4581)

Flange connection

- » EN 1092 PN 10/16 (Design A/B)
- » ASME B16.5 Class 150 lbs (Design RF, FF)
- » DIN 28459

Testing

- » EN 12266 P10
- » EN 12266 P11
- » EN 12266 P12 Leak rate A

PTFE lining

- » void-free
- » isostatic pressed
- » high density (min. 2.16 g/cm³)
- » lining thickness min. 3 mm
- » vacuum lining up to 10 mm available

Vacuum tightness

- » $q^{He}_{max} < 10^{-6}$ mbar 1·s⁻¹

Identification

- » DIN EN 19
- » AD 2000 data sheet A4

Valve disc alignment

- » Centrally, i.e. energy-saving

Characteristic

- » Linear

The correct material choice for your application

Valve Material						Design Type					
1 Valve Body		2 Body Liner		3 Disc		4 Specific Design Body Liner		5 Valve Type		6 Body Type	
Code	Material	Code	Material	Code	Material	Code	Material	Code	Material	Code	Material
1	EN-JS 1049 (0.7043)	1	PTFE**	1	PTFE**	A	Antistatic (SAFETY-SEAL)	V	Vacuum	W	WAFER Ring Body
2	GS-C 25 (1.0619)	2	UHMWPE***	2	UHMWPE***	C	Abrasive service	SV	Special vacuum	L	LUG Flange-On-Body
3	Stainless steel (1.4581)			3	Stainless steel (1.4581)	S	STERILE-SEAL				MOBILE-SEAL
				4	Hastelloy C* (2.4602)					Code	With existing pipe flanges
				5	Titanium* (3.7035)					W-T	MOBILE-SEAL Wafer
										L-T	MOBILE-SEAL Lug
										W-TW	MOBILE-SEAL Drilling according to DIN 28459

Examples	1	2	3	4	5	6	
GAR-SEAL Wafer Design	1	1	1	-	-	W	MT
SAFETY-SEAL Lug Design	3	1	1	A	-	L	MT
MOBILE-SEAL Wafer Design, acc. to TW Standard	1	1	1	-	-	W-TW	MT
STERILE-SEAL Lug Design, antistatic	3	1	3	S	-	L	
SAFETY-SEAL Wafer Design, antistatic	2	1	1	A	-	W	MT
GAR-SEAL Wafer Design, vacuum lining	1	1	1	-	V	W	MT

Performance Data:
DN 50 - 600, 2" - 24"

Nominal Pressure:
max. 16 bar (<DN 300)
Vacuum up to 1 mbar absolute
(depending upon temperature)

Operating temperature:
-40 °C up to +200 °C (for PTFE**)
-40 °C up to +85 °C (for UHMWPE***)
MT = GAR-SEAL Butterfly Valves
comply with the TA-Luft regulations.

* upon request
** Polytetrafluoroethylene
*** Ultrahighmoleculare Polyethylene

GAR-SEAL

Applications

GAR-SEAL butterfly valves are used where corrosive, abrasive and toxic media need to be controlled. GAR-SEAL valves are used for controlling, throttling and shutting off purposes in the chemical, petrochemical and chlorine industry as well as in electroplating, the paper industry and many other industries.



GAR-SEAL

Dimensions

- » DN 50 / 2" up to DN 600 / 24"

Flange connection

- » EN 1092 PN 10/16 (Design A/B)
- » ASME B16.5 class 150 lbs (design RF/FF)

Face-to-face dimensions

- » DIN EN 558-1 GR 20, (DN 350 GR25)
- » ISO 5752 Table 5 short
- » ASME B16.10 (2" to 12" Table Narrow 14" to 24" Table Wide)
- » MSS-SP 67 (2" to 12" Table Narrow 14" to 24" Table Wide)
- » API 609 (2" to 12" Category A Table 2 14" to 24" Category B Table 3)

Body strength

- » DIN/ EN 12516 T2 (DIN 3840)
- » tested within the scope of the inspection body designate by Module H1

Operating pressure

- » DN 50/2" - 300/12": 16 bar
- » above DN 300/12": 10 bar (depending on operating temperature)

Testing

- » EN 12266 P10
- » EN 12266 P11
- » EN 12266 P12 Leak rate A

Bodies

- » Wafer and Lug design with long neck for insulation

Vacuum

- » up to 1 mbar absolute (depending on size and temperature)

Temperature range

- » -40 °C up to +200 °C
- » -40 °F up to +392 °F (depending on material)

Head flange

- » EN ISO 5211
- » NF E 29-402

Liner

- » PTFE
- » Abrasive PTFE
- » UHMWPE

SAFETY-SEAL

Applications

SAFETY-SEAL valves are used in applications where corrosive, abrasive and toxic media need to be insulated against electrostatic charges. SAFETY-SEAL valves offer long life and reduced maintenance effort and extra safety.



SAFETY-SEAL

Dimensions

- » DN 50 / 2" up to DN 600 / 24"

Flange connection

- » EN 1092 PN 10/16 (Design A/B)
- » ASME B16.5 class 150 lbs (design RF/FF)

Face-to-face dimensions

- » DIN EN 558-1 GR 20, (DN 350 GR25)
- » ISO 5752 Table 5 short
- » ASME B16.10 (2" to 12" Table Narrow 14" to 24" Table Wide)
- » MSS-SP 67 (2" to 12" Table Narrow 14" to 24" Table Wide)
- » API 609 (2" to 12" Category A Table 2 14" to 24" Category B Table 3)

Body strength

- » DIN/ EN 12516 T2 (DIN 3840)
- » tested within the scope of the inspection body designate by Module H1

Operating pressure

- » DN 50/2" - 300/12": 16 bar
- » above DN 300/12": 10 bar (depending on operating temperature)

Testing

- » EN 12266 P10
- » EN 12266 P11
- » EN 12266 P12 Leak rate A

Bodies

- » Wafer and Lug design with long neck for insulation

Vacuum

- » up to 1 mbar absolute (depending on size and temperature)

Temperature range

- » -40 °C up to +200 °C
- » -40 °F up to +392 °F (depending on material)

Head flange

- » EN ISO 5211
- » NF E 29-402

Liner

- » Antistatic PTFE

MOBILE-SEAL

Applications

MOBILE-SEAL valves are used on road tanker vehicles, railway wagons, silos and other transportation and storage containers where high chemical resistance, reliability and special safety requirements are essential.



MOBILE-SEAL

Dimensions

- » DN 50/ 2" up to DN 100 / 4" DIN 28459
- » DN 50/ 2" up to DN 150 / 6" EN 1092

Flange connection

- » EN 1092 PN 10/16 (Design A/B)
- » ASME B16.5 class 150 lbs (design RF/FF)
- » DIN 28459 PN10

Face-to-face dimensions

- » DIN EN 558-1 GR 20
- » ISO 5752 Table 5 short
- » ASME B16.10 (2" to 4" Table Narrow)
- » MSS-SP 67 (2" to 4" Table Narrow)
- » API 609 (2" to 4" Category A Table 2)

Body strength

- » DIN/ EN 12516 T2 (DIN 3840)
- » tested within the scope of the inspection body designate by Module H1

Operating pressure

- » DN 50/2" - 100/4": 10 bar (depending on operating temperature)

Testing

- » EN 12266 P10
- » EN 12266 P11
- » EN 12266 P12 Leak rate A

Bodies

- » Wafer and Lug design with long neck for insulation

Vacuum

- » up to 1 mbar absolute

Temperature range

- » -40 °C up to +200 °C
- » -40 °F up to +392 °F (depending on material)

Head flange

- » EN ISO 5211
- » NF E 29-402

Certification

- » EN 14432
- » TÜ-AGG 044-84

Liner

- » PTFE
- » Antistatic PTFE
- » Abrasive PTFE
- » UHMWPE

GAR-SEAL, SAFETY-SEAL, MOBILE-SEAL

Materials

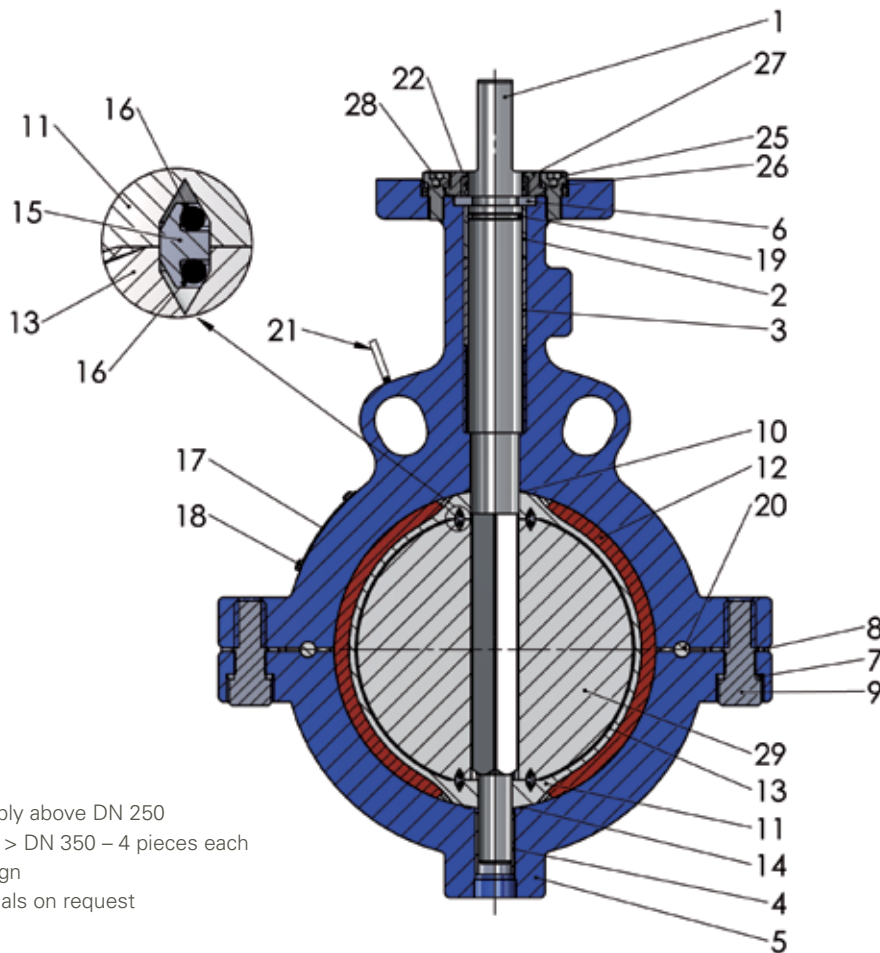

- ¹ does not apply above DN 250
- ² Dimensions > DN 350 – 4 pieces each
- ³ Special design
- ⁴ other materials on request

Pos.	Qty.	Material	Designation	Pos.	Qty.	Material	Designation
1	1	1.4313 up to DN 300 1.4021 from DN 350	Shaft	14*	1	GYLON®	Bottom gasket
				15*	2	PTFE	Sealring
2	1	Steel/PTFE	Slide bushing (top)	16*	4 ⁴	Viton	O-Ring (Sealring)
3	2	Steel/PTFE	Slide bushing (center)	17	1	Stainless steel	Nameplate
4	1	Steel/PTFE	Slide bushing (bottom)	18	4	Stainless steel	Rivet
5	1	see material table	Body	19	1 ⁴	Viton	O-Ring
6	1 ¹	PTFE, carbon reinf.	Retaining ring (split)	20*	2	PTFE	Security element
7	2 ²	Stainless steel	Spring washer	21	1 ³	Steel electroplated	Ground connection
8*	2 ²	GYLON®	Washer	22	2 ⁴	Viton	O-Ring (adapter flange)
9	2 ²	Stainless steel	Body screw	25	4	Stainless steel	Screw
10*	1	GYLON®	Top gasket	26	4	Stainless steel	Spring washer
11*	1	see material table	Lining	27	1	Stainless steel	Head flange
12*	2 ⁴	Silicone	Elastomer backup-element	28	1	GYLON®	Seal (adapter flange)
13*	1	see material table	Disc	29	1	up to DN 65 1.4404 from DN 80 0.7040 (GGG 40)	Disc insert (only PTFE and UHMWPE lined disc)

* Spare parts kit (for metallic disc valves without the disc)

GAR-SEAL, SAFETY-SEAL, MOBILE-SEAL

Dimensions, Wafer

Flange connection:	EN 1092 (DIN 2501), PN 10 • PN 16 • ANSI B 16.5, 150 LBS
Overall length:	EN 558-1 GR20 (DIN 3202 T3 K1) and ASME B16.10
Head flange:	EN ISO 5211

DN 50 - 300

2" - 12"

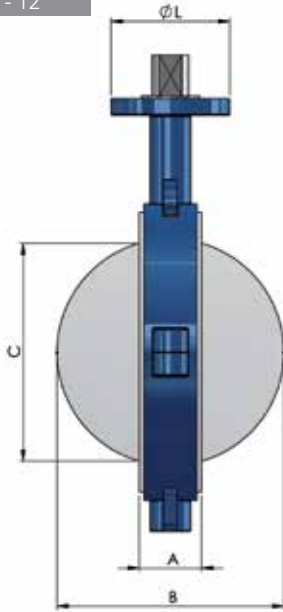

DN 350 - 600

14" - 24"

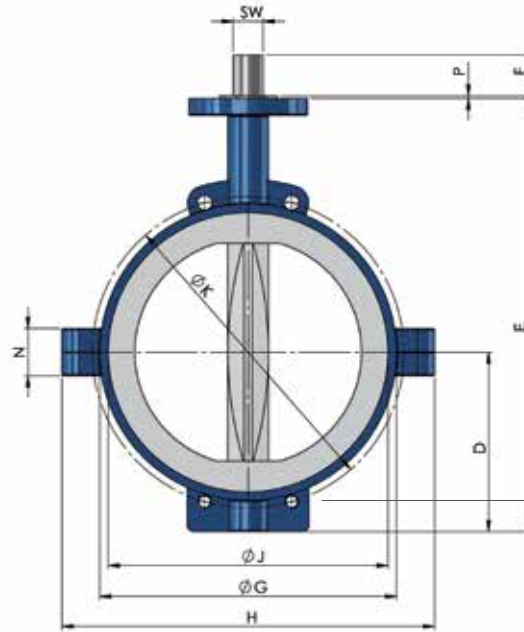

Note:
Lower centering drillings
only from DN350/14"

DN	Inch mm	Head flange **	A	B	C	D	E	F	Ø G	H	Ø J	Ø K		Ø L	SW	P	N	Z		Weight kg **
												EN PN10	ASME 150lbs					EN PN 10	ASME 150 lbs	
2	50	F05	43	60	43	62	202	35	102	152	98	125	121	65	10,0	3	40	4xM16	4x5/8"-11	2,6
2 ½	65	F05	46	70	53	70	220	35	121	171	120	145	140	65	10,0	3	40	4xM16	4x5/8"-11	3,5
3	80	F05	46	82	67	79	244	35	133	183	127	160	152	65	10,0	3	40	8xM16	4x5/8"-11	3,8
4	100	F07	52	106	93	95	275	35	162	214	159	180	190	90	13,0	3	50	8xM16	8x5/8"-11	6,2
5	125	F07	56	128	115	108	303	35	192	248	187	210	216	90	13,0	3	50	8xM16	8x3/4"-10	8,6
6	150	F10	56	157	147	121	336	40	218	290	216	240	241	125	17,0	3	56	8xM20	8x3/4"-10	11,6
8	200	F10	60	197	188	150	395	40	273	350	270	295	298	125	17,0	3	56	8xM20	8x3/4"-10	17,4
10	250	F12	68	246	236	179	459	50	328	405	324	350	362	150	22,0	3	60	12xM20	12x7/8"-9	30,6
12	300	F12	78	295	284	216	536	50	378	455	375	400	432	150	22,0	3	70	12xM20	12x7/8"-9	38,3
14	350	F14	92*	335	322	265	640	60	438	550	413	460	476	175	44,4	4	70	16xM20	12x 1"-8	71,5
16	400	F14	102	387	374	305	725	60	489	570	470	515	540	175	44,4	4	70	16xM24	16x 1"-8	90,6
18	450	F16	114	430	415	320	780	80	539	670	533	565	578	210	44,4	4	70	20xM24	16x1 1/8"-7	113,0
20	500	F16	127	484	467	355	865	80	594	690	584	620	635	210	44,4	4	70	20xM24	20x1 1/8"-7	163,5
24	600	F25	154	578	558	415	990	90	695	820	692	725	749	300	63,5	5	76	20xM27	20x1 1/4"-7	254,0

MOBILE-SEAL
GAR-SEAL + SAFETY-SEAL

8	200	for PN 16 > DN 150	EN PN16	295		12xM20	
10	250		355		12xM24		
12	300		410		12xM24		

*GR 25 ** EN ISO 5211; all dimensions in millimeters (mm), if not indicated differently

** Weight for version 111-W

GAR-SEAL, SAFETY-SEAL, MOBILE-SEAL

Dimensions, Lug

Flange connection:	EN 1092 (DIN 2501), PN 10 • PN 16 • ANSI B 16.5, 150 LBS
Overall length:	EN 558-1 GR20 (DIN 3202 T3 K1) and ASME B16.10
Head flange:	EN ISO 5211

DN 50 - 300
2" - 12"

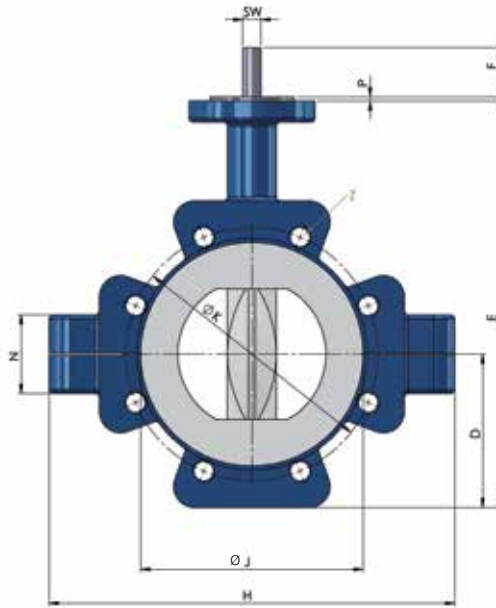
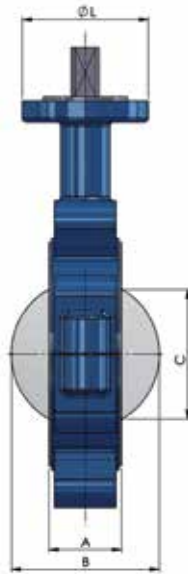

DN 350 - 600
14" - 24"

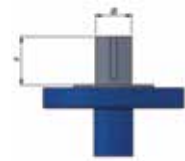

DN	Inch mm	Head flange **	A	B	C	D	E	F	H	Ø J	Ø K		Ø L	SW	P	N	Z		Weight kg **
											EN PN10	ASME 150lbs					EN PN 10	ASME 150 lbs	
2	50	F05	43	60	43	62	202	35	170	98	125	121	65	10,0	3	45	4xM16	4x5/8"-11	3,6
2 ½	65	F05	46	70	53	70	220	35	193	120	145	140	65	10,0	3	45	4xM16	4x5/8"-11	4,5
3	80	F05	46	82	67	91	256	35	252	127	160	152	65	10,0	3	56	8xM16	4x5/8"-11	7,1
4	100	F07	52	106	93	109	289	35	290	159	180	190	90	13,0	3	56	8xM16	8x5/8"-11	10,2
5	125	F07	56	128	115	120	315	35	312	187	210	216	90	13,0	3	60	8xM16	8x3/4"-10	12,7
6	150	F10	56	157	147	136	351	40	312	216	240	241	125	17,0	3	66	8xM20	8x3/4"-10	17,3
8	200	F10	60	197	188	163	408	40	416	270	295	298	125	17,0	3	76	8xM20	8x3/4"-10	27,0
10	250	F12	68	246	236	200	480	50	508	324	350	362	150	22,0	3	90	12xM20	12x7/8"-9	41,5
12	300	F12	78	295	284	233	553	50	575	375	400	432	150	22,0	3	110	12xM20	12x7/8"-9	60,5
14	350	F14	92*	335	322	265	640	60	640	413	460	476	175	44,4	4	70	16xM20	12x1"-8	108,0
16	400	F14	102	387	374	305	725	60	720	470	515	540	175	44,4	4	70	16xM24	16x1"-8	137,5
18	450	F16	114	430	415	320	780	80	750	533	565	578	210	44,4	4	70	20xM24	16x1 1/8"-7	153,9
20	500	F16	127	484	467	366	876	80	830	584	620	635	210	44,4	4	70	20xM24	20x1 1/8"-7	256,0
24	600	F25	154	578	558	415	990	90	960	692	725	749	300	63,5	5	76	20xM27	20x1 1/4"-7	395,0

MOBILE-SEAL
GAR-SEAL + SAFETY-SEAL

DN	mm	EN PN16	Z	Weight kg **
8	200	295	12xM20	
10	250	355	12xM24	
12	300	410	12xM24	

for PN 16 > DN 150

*GR 25 ** EN ISO 5211; all dimensions in millimeters (mm), if not indicated differently

** Weight for version 111-L

MOBILE-SEAL

Dimensions, Wafer tank truck

Flange connection:	DIN 28459 PN 10
Overall length:	EN 558-1 GR20 (DIN 3202 T3 K1)
Head flange:	EN ISO 5211

DN 50 - 65

2" - 2½"

DN 80 - 100

3" - 4"

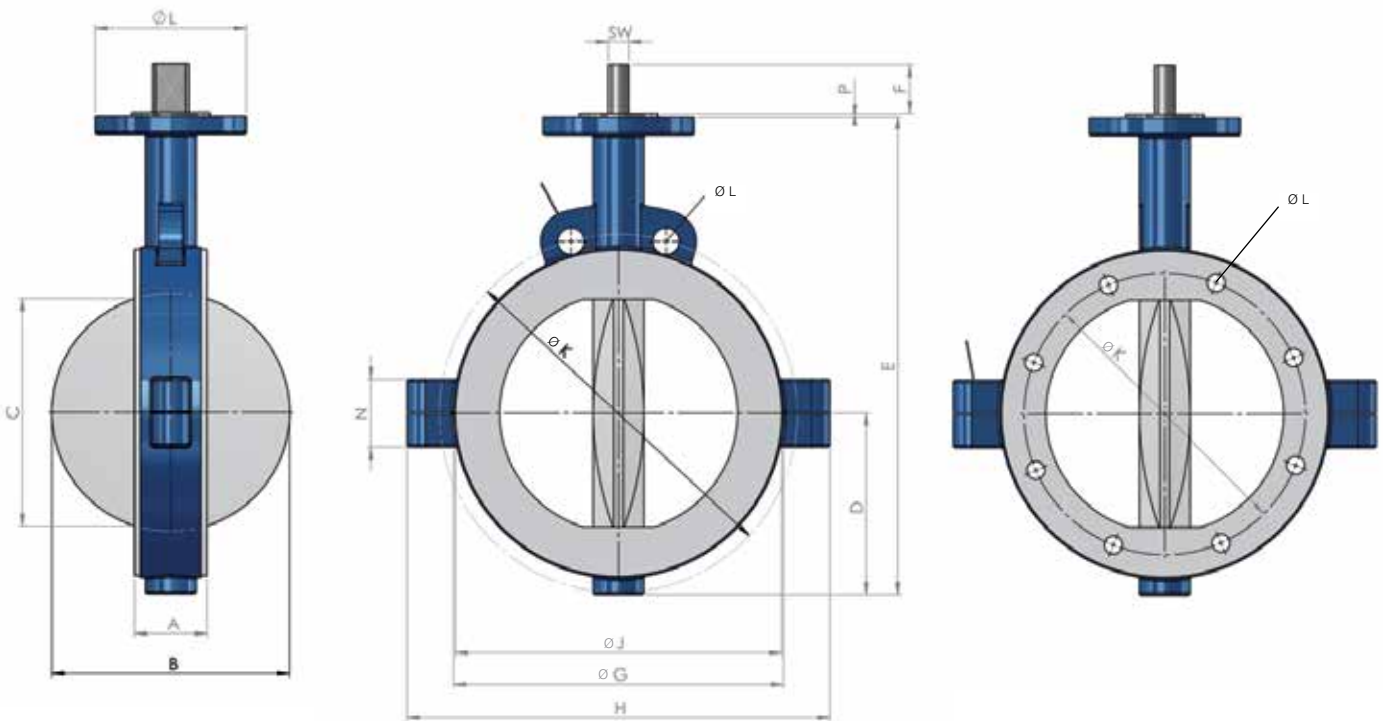

	DN		Head flange **	A	B	C	D	E	F	ØG	H	ØJ	ØK	ØL	SW	P	N	O	Z	Weight kg **
	Inch	mm																		
MOBILE-SEAL	2	50	F05	43	60	43	62	202	35	102	152	98	130	65	10	3	40	11	8xM10	2,6
	2½	65	F05	46	70	53	70	220	35	121	171	120	130	65	10	3	40	11	8xM10	3,5
	3	80	F05	46	82	67	82	244	35	154	183	127	130	65	10	3	40	11	8xM10	3,7
	4	100	F07	52	106	93	106	275	35	174	217	159	150	90	13	3	40	14	8xM12	6,2

** EN ISO 5211; all dimensions in millimeters (mm), if not indicated differently

** Weight for version 111-W-TW

STERILE-SEAL

Applications

STERILE-SEAL valves are used where sterile processes need to be maintained in the pharmaceutical and food industries without unnecessary and costly overhauls and replacement. The special characteristic of this valve is its external sterilization capability. By the design of the valve the critical „dead“ areas of the valve, as well as the disc, body liner and seals, can be sterilized with steam without contact to the process.



STERILE-SEAL

Dimensions

- » DN 50 / 2" up to DN 400 / 16"

Flange connection

- » EN 1092 PN 10/16 (Design A/B)
- » ASME B16.5 class 150 lbs (design RF/FF)

Face-to-face dimensions

- » DIN EN 558-1 GR 20 (DN 350 GR25)
- » ISO 5752 Table 5 short
- » ASME B16.10 (2" to 12" Table Narrow 14" to 16" Table Wide)
- » MSS-SP 67 (2" to 12" Table Narrow 14" to 16" Table Wide)
- » API 609 (2" to 12" Category A Table 2 14" to 16" Category B Table 3)

Body strength

- » DIN/ EN 12516 T2 (DIN 3840)
- » tested within the scope of the inspection body designate by Module H1

Operating pressure

- » DN 50/2" - 400/16": 10 bar (depending on operating temperature)

Testing

- » EN 12266 P10
- » EN 12266 P11
- » EN 12266 P12 Leak rate A

Bodies

- » Wafer and Lug design with long neck for insulation

Vacuum

- » up to 1 mbar absolute (depending on operating temperature)

Temperature range

- » -40 °C up to +170 °C
- » -40 °F up to +338 °F (depending on material)

Head flange

- » EN ISO 5211
- » NF E 29-402

Liner

- » PTFE

STERILE-SEAL

No survival for bacteria

For fermentation, sterile processing is the premise to guarantee the optimum productivity of the used microorganisms. All bacteria have to be destroyed before fermentation and also all products fed into the process have to be sterilized. Most important is the avoidance of any contamination during fermentation up to the separation of the biomass and treatment of the final product.

The new re-designed STERILE-SEAL valve with its steam blocking chambers surround and protect the product area against external pollution, even under vacuum conditions. This design is a major breakthrough for large scale biotechnology plants. With the STERILE-SEAL valve bacteria contamination is a thing of the past.

Construction

The media in the inner chamber is protected against contamination by the surrounding isolation chambers which are directly connected to the inner sealing system. A second outer sealing system separates the process from the atmosphere. STERILE-SEAL valves are completely void and cavity-free to prevent any build-up of nutrients.

Operation Principle

Pressurized steam is fed into the steam inlet and distributed through the longitudinal channels of the shaft and out through the flow control at the bottom of the valve body. It is also possible to seal the valve by pressuring the isolation chambers and closing the steam outlet connection.

Sterilization Proof

During tests, STERILE-SEAL valves were contaminated at several points with *Bacillus Stearothermophilus* with a population of $5,7 \times 10^5$. Pressurized steam was then allowed to flow through the two chambers, followed by sterile air. In every instance the bacillus was completely destroyed.

The safe concept

STERILE-SEAL valves meet the highest standards of Garlock's excellence.

For example:

Body

Split-body, manufactured from ductile iron, cast steel or stainless steel. Safety sealing between the two body halves, seals are fitted within the body liner to prevent atmospheric contamination and the escape of media.

Body liner manufactured from high density PTFE, FDA approved, void-free, impermeable, liner thickness 3 mm minimum.

Stainless steel disc

For highest demands, i.e. pyrogenic resistant, particle and fibrous free surfaces with max. 1 % delta-ferrite, content: Forged (WN 1.4435 and others). Surface finishes to $0,1 \mu\text{m Ra}$ are available.

Shaft

One-piece manufactured from stainless steel with ring and longitudinal channels.

Advantages

The STERILE-SEAL concept improves the profitability of production processes in pharmaceutical, food and biotechnology industries.

- » Safety against contamination
- » Safety against corrosion
- » Safety of the body against over-pressurization
- » Safety by standardization
- » Safety against leakages
- » Safety by identification

STERILE-SEAL

2-chamber-system guarantees production safety

PTFE*, isostatically molded. High density, high crystallinity, stainless steel discs. STERILE-SEAL valves are available in wafer and lug design in all sizes from 2" (DN 50) to 16" (DN 400). Actuators of any kind and type can be mounted.

Service pressure:	from vacuum up to 10 bar
Service temperature:	-40 °C to +170 °C , 40 °F to 338 °F

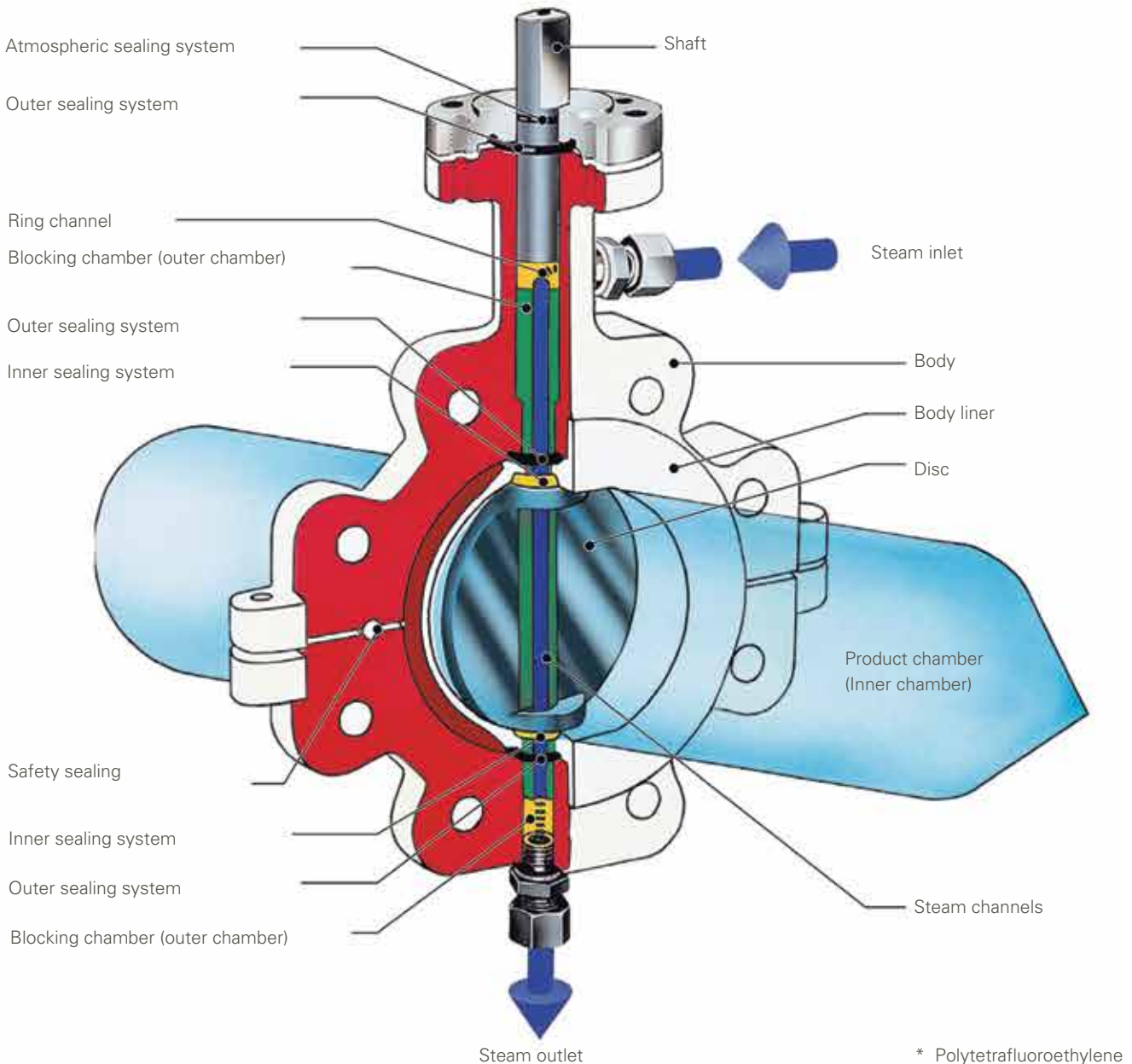

STERILE-SEAL

Materials

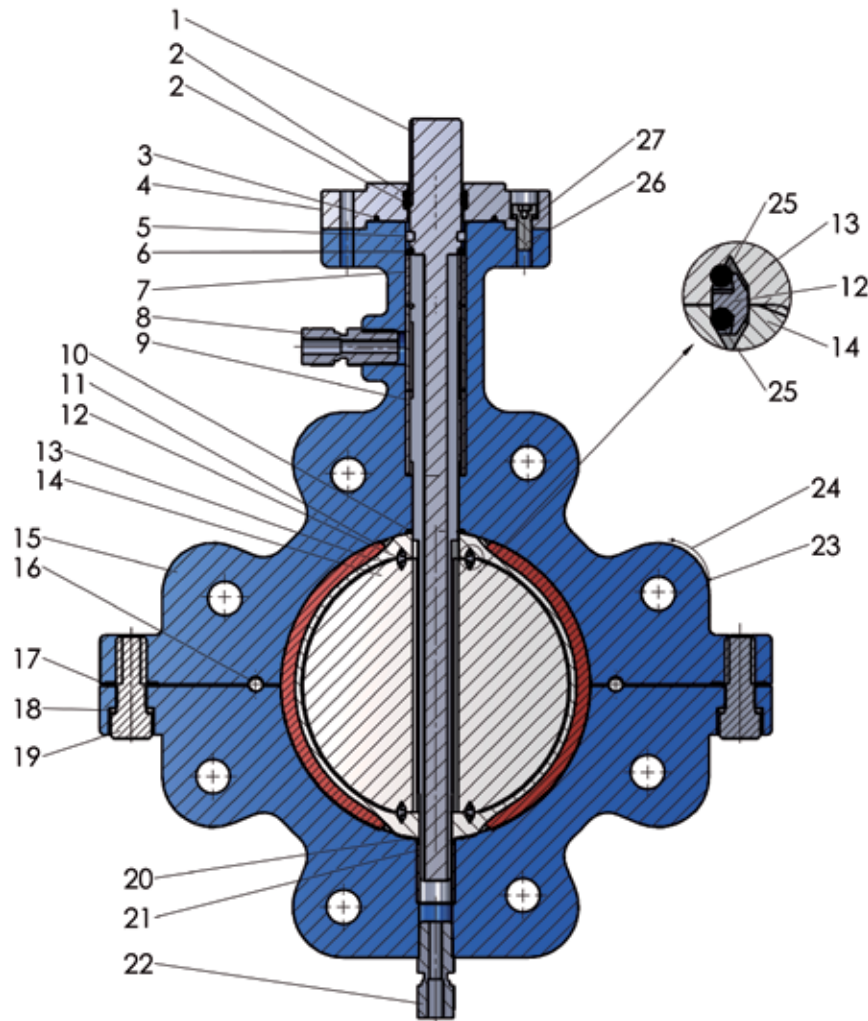

Pos.	Qty.	Material	Designation	Pos.	Qty.	Material	Designation
1	1	1.4313 up to DN 300 1.4021 from DN 350	Shaft	15	1	see material table	Body
				16	2	PTFE	Security element
2	2 ⁴	EPDM	O-Ring (shaft)	17	2 ²	PTFE	Washer
3	1 ⁴	EPDM	O-Ring (top flange)	18	2 ²	Stainless steel	Spring washer
4	1	1.4301	Top flange	19	2 ²	Stainless steel	Body screw
5	1	PTFE, carbon reinf.	Setaining ring (split)	20	1 ⁴	EPDM	O-Ring (liner)
6	1 ⁴	EPDM	O-Ring (shaft)	21	1	Steel/PTFE	Slide bearing (bottom)
7	1	Steel/PTFE	Slide bearing (top)	22	1	Stainless steel	Fitting
8	1	Stainless steel	Fitting	23	4	Stainless steel	Groove pin
9	2	Steel/PTFE	Slide bearing (center)	24	1	Stainless steel	Nameplate
10	1 ⁴	EPDM	O-Ring (liner)	25	4 ⁴	EPDM	O-Ring (Sealring)
11	2 ⁴	EPDM	Elastomer backup element	26	4	Stainless steel	Locking screw
12	2	PTFE	Sealring	27	4	Stainless steel	Spring washer
13	1	see material table	Liner				
14	1	see material table	Valve disc				

² > DN 350 – 4 pieces each
⁴ other materials on request

STERILE-SEAL

Dimension, Wafer

Flange connection: EN 1092 (DIN 2501), PN 10 • PN 16 • ANSI B 16.5, 150 LBS
Overall length: EN 558-1 GR20 (DIN 3202 T3 K1)
Head flange: EN ISO 5211

DN 50 - 300
2" - 12"

DN 350 - 400
14" - 16"

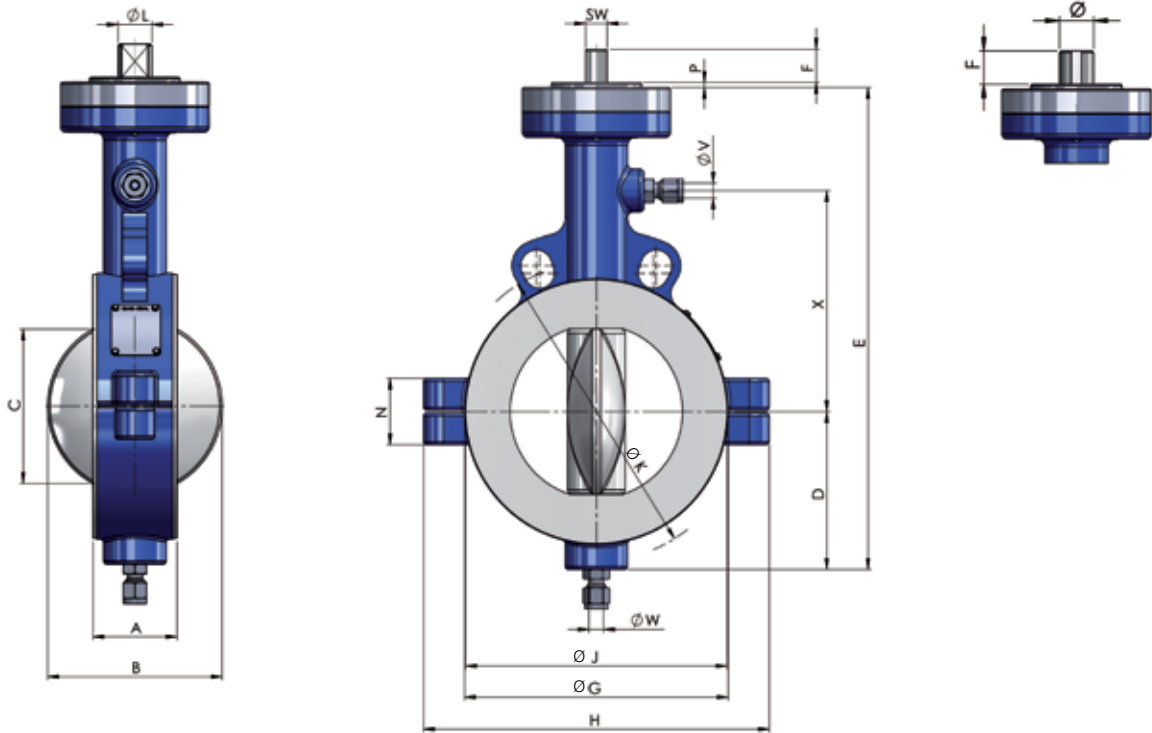

DN Inch mm	Head flange **	A	B	C	D	E	F	Ø G	H	Ø J	K		Ø L	SW	P	N	Ø V	Ø W	Z		X	Weight kg **									
											EN PN10	ASME 150lbs							EN PN10	ASME 150 lbs											
2	50	F05	43	60	43	62	214	35	102	152	98	125	121	65	10,0	3	40	10	10	4xM16	4x5/8"-11	103	3,0								
2 ½	65	F05	46	70	53	70	232	35	121	181	120	145	140	65	10,0	3	40	12	12	4xM16	4x5/8"-11	113	4,1								
3	80	F05	46	82	67	79	256	35	133	183	127	160	152	65	10,0	3	40	12	12	8xM16	4x5/8"-11	128	4,5								
4	100	F07	52	106	93	95	290	35	162	214	159	180	190	90	13,0	3	50	12	12	8xM16	8x5/8"-11	133	7,0								
5	125	F07	56	128	115	108	318	35	192	248	187	210	216	90	13,0	3	50	12	12	8xM16	8x3/4"-10	148	9,5								
6	150	F10	56	157	147	121	351	40	218	290	216	240	241	125	17,0	3	56	12	12	8xM20	8x3/4"-10	168	12,9								
8	200	F10	60	197	188	150	410	40	273	350	270	295	298	125	17,0	3	56	12	12	8xM20	8x3/4"-10	198	18,1								
10	250	F12	68	246	236	179	474	50	328	405	324	350	362	150	22,0	3	60	18	18	12xM20	12x7/8"-9	228	29,7								
12	300	F12	78	295	284	216	551	50	378	455	375	400	432	150	22,0	3	70	18	18	12xM20	12x7/8"-9	258	38,6								
14	350	F14	92*	335	322	265	670	60	438	550	413	460	476	175	44,4	4	70	25	25	16xM20	12x1"-8	314	77,2								
16	400	F14	102	387	374	305	755	60	489	570	470	515	540	175	44,4	4	70	25	25	16xM24	16x1"-8	359	94,9								
8	200	for PN 16 > DN 150										295											12xM20								
10	250											355																		12xM24	
12	300											410																			12xM24

*GR 25 ** EN ISO 5211; all dimensions in millimeters (mm), if not indicated differently

** Weight for version 111-S-W

STERILE-SEAL

Dimension, Lug

Flange connection:	EN 1092 (DIN 2501), PN 10 • PN 16 • ANSI B 16.5, 150 LBS
Overall length:	EN 558-1 GR20 (DIN 3202 T3 K1)
Head flange:	EN ISO 5211

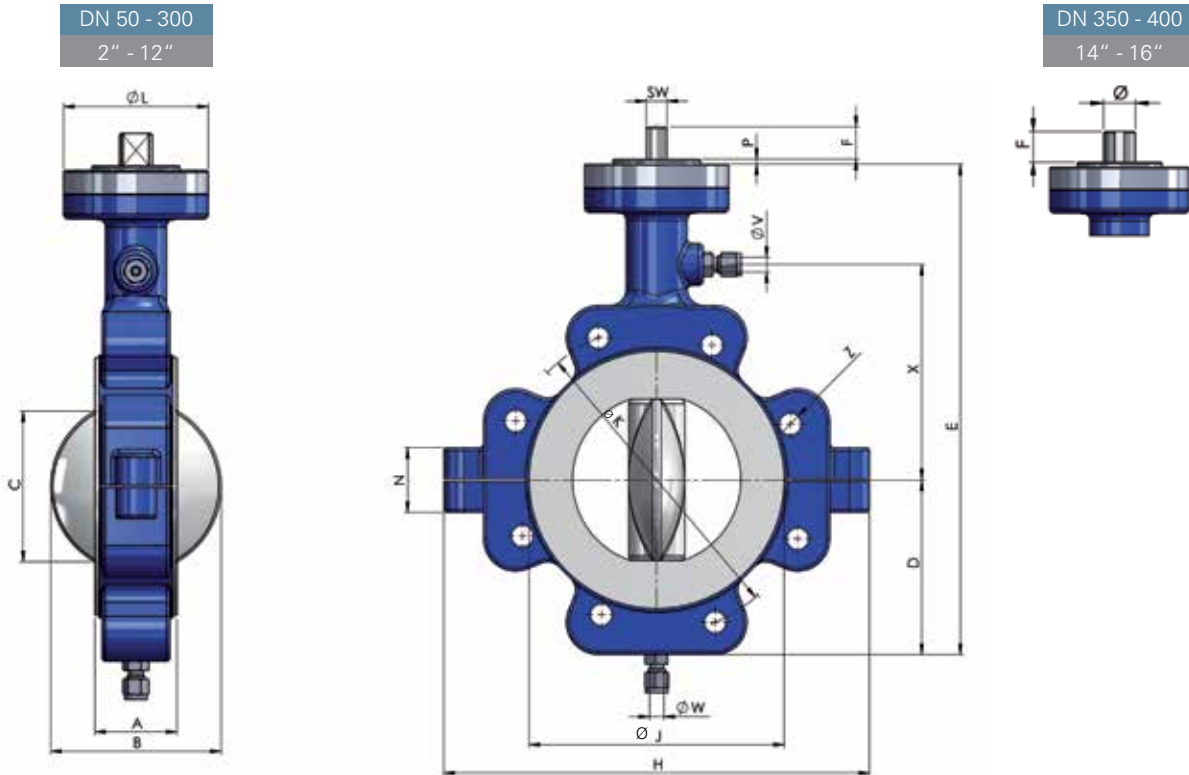

DN		Head flange **	A	B	C	D	E	F	H	Ø J	Ø K		Ø L	SW	P	N	Ø V	Ø W	Z		X	Weight kg **	
Inch	mm										EN PN10	ASME 150 lbs							EN PN10	ASME 150 lbs			
2	50	F05	43	60	43	62	214	35	170	98	125	121	65	10,0	3	45	10	10	4xM16	4x5/8"-11	103	3,8	
2 ½	65	F05	46	70	53	70	232	35	193	120	145	140	65	10,0	3	45	12	12	4xM16	4x5/8"-11	113	4,8	
3	80	F05	46	82	67	79	256	35	252	193	160	152	65	10,0	3	56	12	12	8xM16	4x5/8"-11	128	7,0	
4	100	F07	52	106	93	95	290	35	290	252	180	190	90	13,0	3	56	12	12	8xM16	8x5/8"-11	133	11,1	
5	125	F07	56	128	115	108	318	35	312	187	210	216	90	13,0	3	60	12	12	8xM16	8x3/4"-10	148	13,5	
6	150	F10	56	157	147	121	351	40	362	216	240	241	125	17,0	3	66	12	12	8xM20	8x3/4"-10	168	17,8	
8	200	F10	60	197	188	150	410	40	416	270	295	298	125	17,0	3	76	12	12	8xM20	8x3/4"-10	198	24,1	
10	250	F12	68	246	236	179	474	50	508	324	350	362	150	22,0	3	90	18	18	12xM20	12x7/8"-9	228	39,4	
12	300	F12	78	295	284	234	551	50	575	375	400	432	150	22,0	3	110	18	18	12xM20	12x7/8"-9	258	55,0	
14	350	F14	92*	335	322	265	670	60	640	413	460	476	175	44,4	4	70	25	25	16xM20	12x1"-8	314	108,2	
16	400	F14	102	387	374	305	755	60	720	470	515	540	175	44,4	4	79	25	25	16xM24	16x1"-8	359	137,4	
8	200	for PN 16 > DN 150										295									12xM20		
10	250	for PN 16 > DN 150										355									12xM24		
12	300	for PN 16 > DN 150										410									12xM24		

*GR 25 ** EN ISO 5211; all dimensions in millimeters (mm), if not indicated differently

** Weight for version 111-S-L

STERILE-SEAL

Exploded View

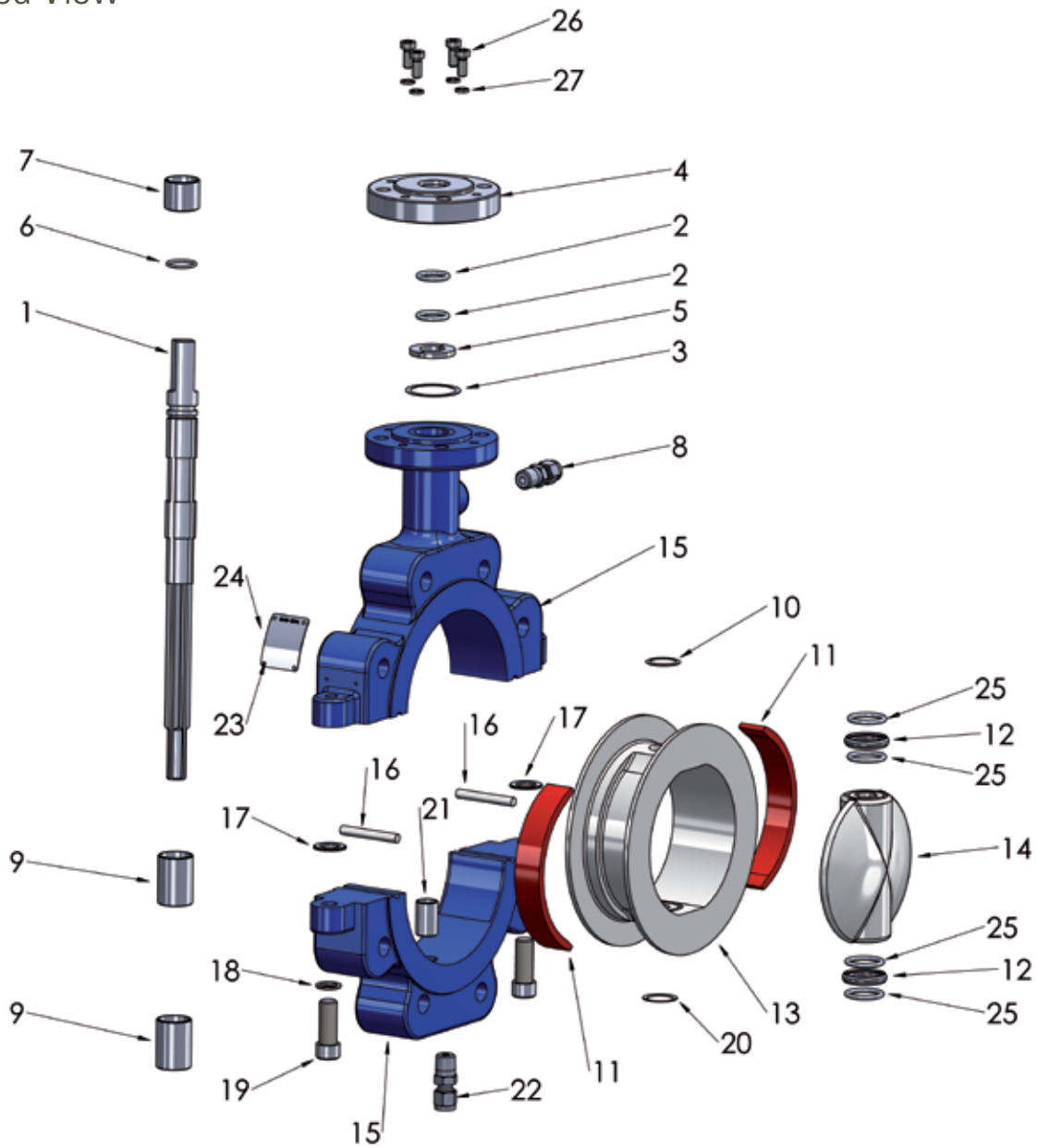

Pos.	Designation	Pos.	Designation	Pos.	Designation	Pos.	Designation
1	Shaft	8	Fitting	15	Body	22	Fitting
2	O-Ring (shaft)	9	Slide bearing (center)	16	Security element	23	Groove pin
3	O-Ring (top flange)	10	O-Ring (liner)	17	Washer	24	Name plate
4	Top flange	11	Elastomer back-up	18	Spring washer	25	O-Ring (Sealing)
5	Retaining ring (split)	12	Seal ring	19	Body screw	26	Locking screw
6	O-Ring (shaft)	13	Liner	20	O-ring (liner)	27	Spring washer
7	Slide bearing (top)	14	Disc	21	Slide bearing (bottom)		

Head flange

Dimensions

According to EN ISO 5211

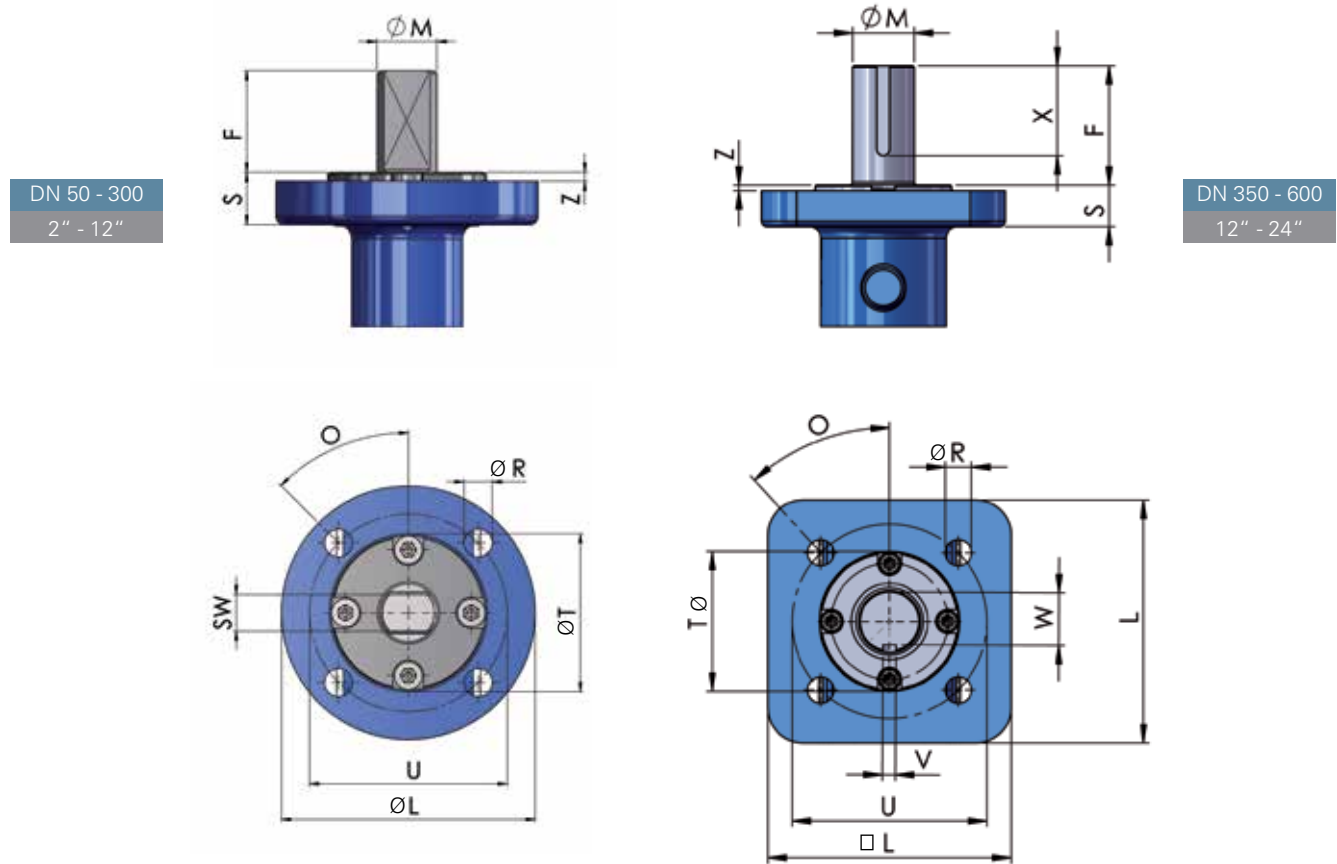

DN		Head flange *	F	SW	Ø L	Ø M	O	n x Ø R	S**	S***	U	Ø T	Z	V	W	X
Inch	mm															
2, 2 1/2, 3	50, 65, 80	F05	35	10	65	14,2	45°	4 x 7	15	27	50	35	3	-	-	-
4, 5	100, 125	F07	35	13	90	20,5	45°	4 x 9	18	33	70	55	3	-	-	-
6, 8	150, 200	F10	40	17	125	25,3	45°	4 x 11	18	33	102	70	3	-	-	-
10, 12	250, 300	F12	50	22	150	32,4	45°	4 x 13	21	36	125	85	3	-	-	-
14, 16	350, 400	F14	60	-	175	44,4	45°	4 x 17	34	64	140	100	4	9,5	39	55
18, 20	450, 500	F16	80	-	210	44,4	45°	4 x 22	44	-	165	130	4	9,5	39	55
24	600	F25	90	-	300	63,5	22,5°	8 x 17	60	-	254	200	5	16,0	54	70

* EN ISO 5211

all dimensions in millimeters (mm), if not indicated differently

** GAR-SEAL, SAFETY-SEAL, MOBILE-SEAL

*** STERILE-SEAL

Manual Operators

Hand-Lever

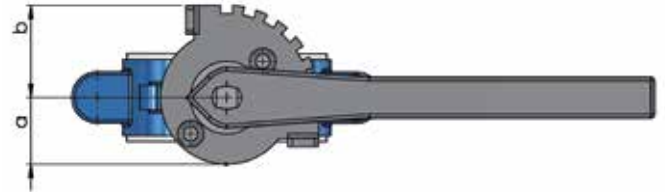
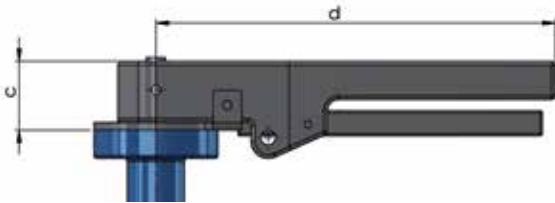

Inch	DN	a	b	c	d	Weight kg
	mm					
2, 2 ½, 3	50, 65, 80	32,5	45	38	210	1,0
4, 5	100, 125	45	57	38	300	1,5
6, 8	150, 200	80	80	43	500	3,5

all dimensions in millimeters (mm), if not indicated differently

ADR-Hand-Lever

ADR Locking handle for hazardous transports

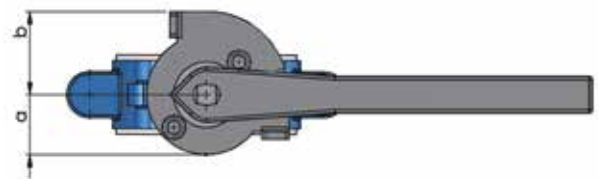
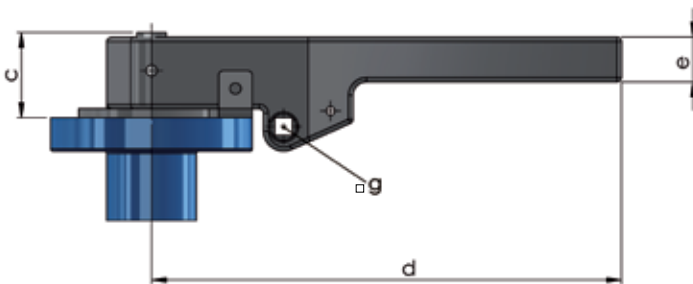

Inch	DN	a	b	c	d	e	□ g	Weight kg
	mm							
2, 2 ½, 3	50, 65, 80	32,5	45	38	210	20	8	0,9
4, 5	100, 125	45	57	38	300	20	8	1,2
6, 8	150, 200	80	80	43	500	26	8	3,1

all dimensions in millimeters (mm), if not indicated differently

Manual Operators

Gear Operator

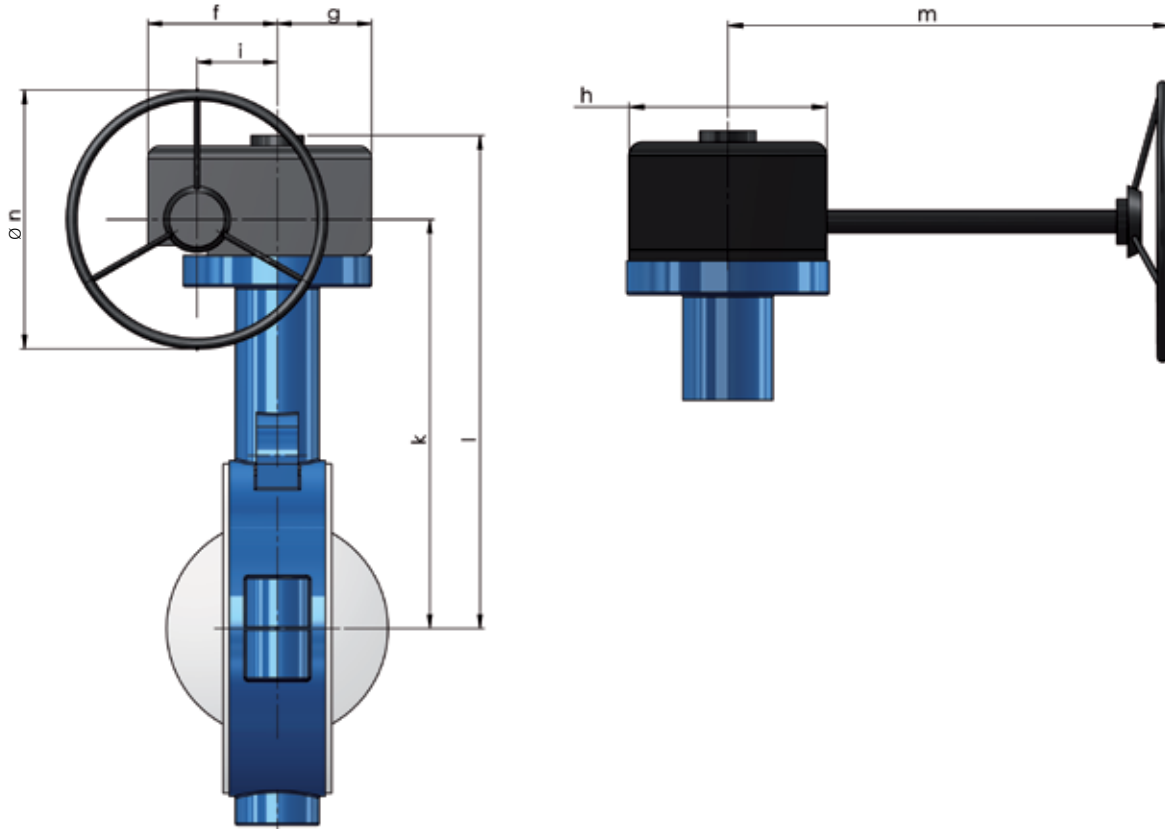

DN		f	g	h	i	k*	l*	k**	l**	m	Ø n	Total weight (kg)	
Inch	mm											Type W Wafer	Type L Lug
2	50	62	45	88	38,5	166,5	198	179,5	210	152	125	6,6	7,4
2 ½	65	62	45	88	38,5	167,5	208	180,5	220	152	125	7,6	8,3
3	80	62	45	88	38,5	191,5	223	203,5	230	152	125	8,0	10,5
4	100	62	45	88	38,5	206,5	238	221,5	253	152	125	10,1	14,2
5	125	62	45	88	38,5	221,5	253	236,5	268	152	125	12,6	16,6
6	150	83,5	58	116	52	250	282	265	297	182	250	18,0	22,9
8	200	83,5	58	116	52	280	312	295	327	182	250	23,2	29,2
10	250	105	75	150	66,7	322	361	337	376	216	300	38,2	47,9
12	300	105	75	150	66,7	362	401	377	416	216	300	47,1	63,5
14	350	131	86	198	89,5	425	468	455	498	283	450	89,0	120,0
16	400	131	86	198	89,5	470	513	500	543	283	450	106,7	149,2
18	450	178	114	252	123	510	566	-	-	335	450	152,4	180,9
20	500	178	114	252	123	560	611	-	-	335	450	184,3	274,8
24	600	209	117	315	154	625	702	-	-	360	450	289,2	427,7

* GAR-SEAL, SAFETY-SEAL, MOBILE-SEAL

** STERILE-SEAL

all dimensions in millimeters (mm), if not indicated differently

Technical Details

Standard Design

For selecting the correct valve actuation the values below represent the maximum torques for the opening and closing action. The torques shown in the table are valid for disc and liner made of the same material: PTFE, antistatic or abrasive. For torque tables for other materials or other material combinations please consult our valves specialists. The stated torques are including a 10 % safety factor at dry condition measured at 21 °C (70 °F).

Torques in Nm

Dimensions		Material	Liner*	PTFE/ antistatic/ abrasive
			Disc	PTFE/ antistatic/ abrasive
Inch	mm		Nm	
2	50			25
2½	65			28
3	80			29
4	100			53
5	125			87
6	150			121
8	200			168
10	250			215
12	300			274
14	350			544
16	400			770
18	450			996
20	500			1089
24	600			2056

*3 mm liner up to DN 300 / 12"
4 mm liner from DN 350 / 14"

P x T - Diagram GAR-SEAL Butterfly Valve

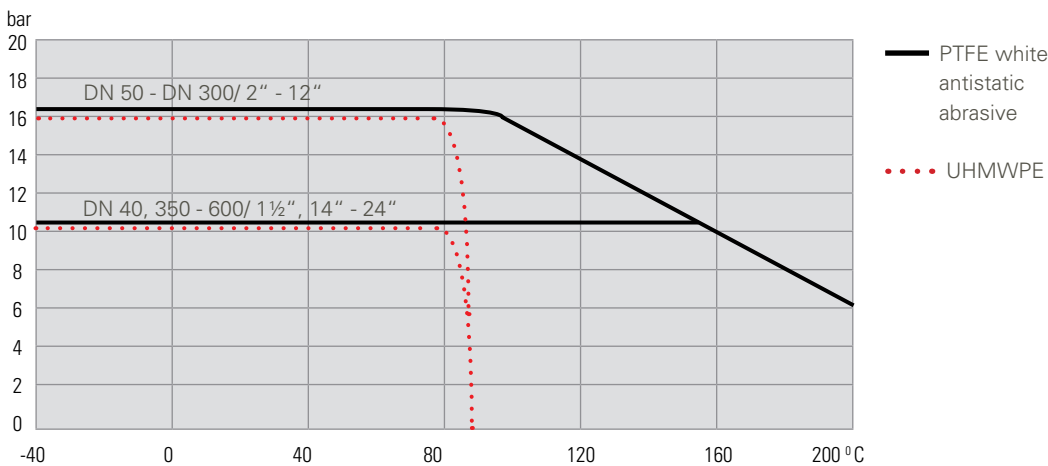

Technical Details

Standard Design

Open/Close control – characteristic curve

The graph shows the percentage flow rate, depending upon the disc-aperture. The curve reflects a throttle valve of any size with slight modifications depending upon thickness and profile of the disc itself. Throttle valves with apertures above 60° should be used for on/off control only.

Angle of aperture

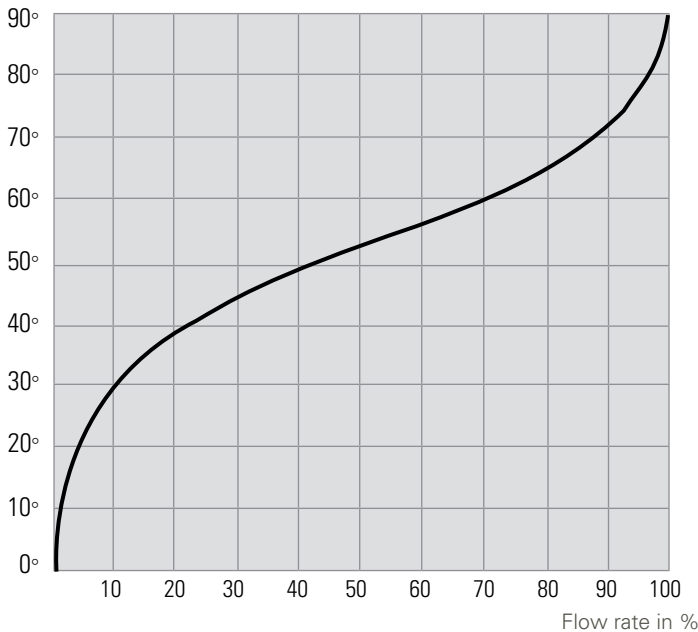

Continuous control / characteristic curve

For continuous control of a throttle valve the flow rate for a 60° aperture is defined with 100 % to provide a flow reserve. The graph has a characteristic of similar percentage for disc opening from 0° to 60°.

Angle of aperture

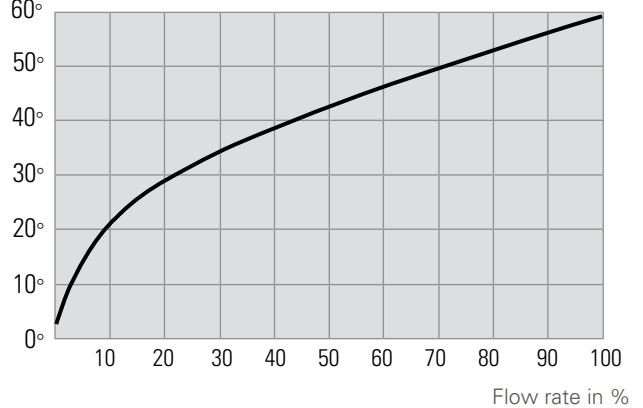

Flow Rate

For liquids the following references apply:
 Constant control: 4,5 m/s
 Open/Close control: 7,5 m/s

For GAR-SEAL Butterfly Valves with UHMWPE-Lining the maximum flow rate is limited to 3,5 m/s.

Nominal bore		kv-factor against the angle of aperture							
Inch	mm	20°	30°	40°	50°	60°	70°	80°	90°
2	50	1	13	25	37	54	69	81	84
2 ½	65	2	16	34	52	82	112	130	132
3	80	2	16	38	80	133	191	243	244
4	100	9	43	87	144	228	316	399	420
5	125	16	61	122	210	262	497	670	710
6	150	22	113	215	364	547	822	972	997
8	200	35	165	332	555	874	1215	1534	1613
10	250	65	301	608	1015	1599	2221	2805	2950
12	300	96	446	900	1504	2369	3291	4157	4371
14	350	136	632	1277	2133	3360	4669	5896	6200
16	400	194	898	1813	3027	4770	6626	8369	8800
18	450	237	1097	2215	3698	5824	8095	10223	10750
20	500	297	1377	2781	4644	7317	10166	12839	13500
24	600	420	1948	3935	6570	10352	14382	18164	19100

kv-values against the angle of aperture

The kv-factor reflects the flow of water (density 1=1000 kg/m³) in m³/h for a pressure gradient of Δp= 1 bar. The resistance characteristic of the butterfly valve is subject to the kv-factor. It replaces all earlier definitions, see cross-section, flow and friction coefficient. A detailed butterfly valve dimensioning for maximum flow and/or for throttle use is performed by CONVAL-Software programming.

Please consult Garlock directly.

Technical Details

Special vacuum design

Garlock valves have for decades operated under extreme vacuum conditions.

Past statements on vacuum stress have been made and documented, but only at ambient temperature and the valve closed. This is very ambiguous to a plant engineer. His requirements are the actual vacuum data at all temperatures. Plant vacuum can go down to 1 mbar together with higher temperatures. This often leads to leakages and malfunctions as the liner can be deformed. Garlock has developed special vacuum versions of its GAR-SEAL valves to meet these particular demands.

Vacuum applications of fluorocarbon lined valves with separate liners are subject to special parameters. Therefore not only the actual vacuum is important, but also the service temperature, the thickness of the liner and its geometry.

Garlock with its successful development program and substantial testing of various sizes, including DN 500, at temperatures up to 200 °C concluded that such extreme service conditions can be handled.

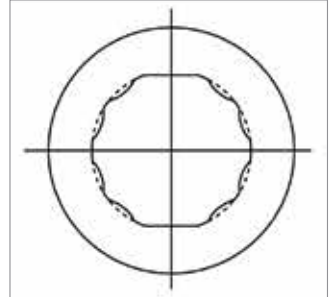

Typical appearance of high vacuum-loaded Body Liner

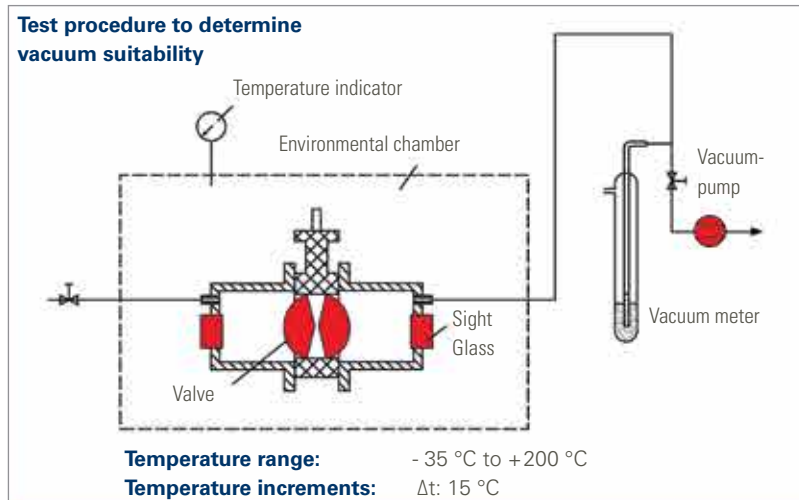

GAR-SEAL Valves can be supplied with varying liner thicknesses for vacuum duties.

The DN 100 size liners show the difference between the standard 3 mm thick and the vacuum 5 mm thick liners. The liner thickness substantially improves the performance against high vacuum stress.

In the DN 100 valve the 3 mm thick liner will operate to 1 mbar, while the 5 mm liner operates below 1 mbar vacuum. Depending on the operating vacuum and temperature and size of valve, the liner thickness can be calculated and selected between 3 mm and 10 mm for GAR-SEAL valves.

Please contact Garlock directly for your specific requirements on vacuum applications.



Technical Details

Data and facts for vacuum design

Facts and figures for the use with vacuum

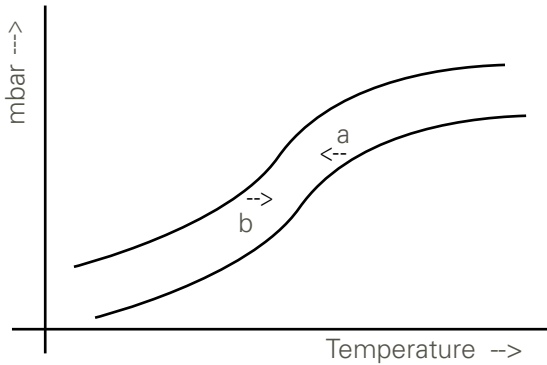

Typical characteristics of body liners under vacuum stress depending on temperature

- a) Increase size and/or decrease liner thickness
DN 1 > DN 2; $s_1 < s_2$
- b) Increasing liner thickness and/or higher moment of resistance by altering geometry
 $s_2 > s_1$

Recommended application limits for GAR-SEAL valves with standard body liners

For applications in vacuum and/or temperatures above these values special body liners are necessary. Please contact Garlock directly.

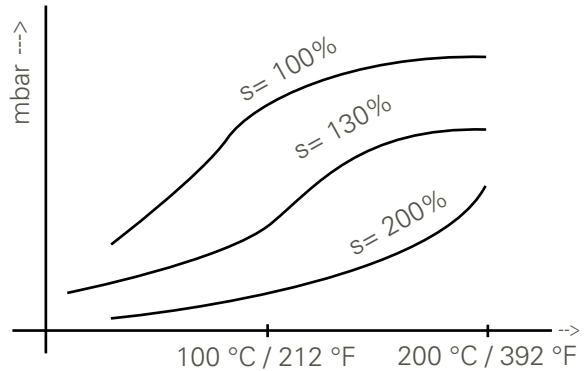

Stress example of Garlock DN 300 body liner with same geometry but different liner thickness "s"

A 30% increase of the liner thickness at a service temperature of 160 °C improves the vacuum resistance by 35 %. A doubling of the lining thickness will lead to a 85 % increase in the vacuum resistance.



Nominal width	Temperature range	Standard liner *	Maximum vacuum liner *
≤ DN 100	≤ 100 °C / 212 °F	1	< 1
	> 100 °C / 212 °F ≤ 150 °C / 302 °F	1	< 1
	> 150 °C / 302 °F ≤ 200 °C / 392 °F	1	< 1
DN 150	≤ 100 °C / 212 °F	5	< 1
	> 100 °C / 212 °F ≤ 150 °C / 302 °F	173	1
	> 150 °C / 302 °F ≤ 200 °C / 392 °F	293	1
DN 200	≤ 100 °C / 212 °F	209	< 1
	> 100 °C / 212 °F ≤ 150 °C / 302 °F	343	< 1
	> 150 °C / 302 °F ≤ 200 °C / 392 °F	438	1
DN 300	≤ 100 °C / 212 °F	471	1
	> 100 °C / 212 °F ≤ 150 °C / 302 °F	561	39
	> 150 °C / 302 °F ≤ 200 °C / 392 °F	624	178
DN 400	≤ 100 °C / 212 °F	498	1
	> 100 °C / 212 °F ≤ 150 °C / 302 °F	583	1
	> 150 °C / 302 °F ≤ 200 °C / 392 °F	643	108
DN 500	≤ 100 °C / 212 °F	599	162
	> 100 °C / 212 °F ≤ 150 °C / 302 °F	667	304
	> 150 °C / 302 °F ≤ 200 °C / 392 °F	715	405
DN 600	≤ 100 °C / 212 °F	737	343
	> 100 °C / 212 °F ≤ 150 °C / 302 °F	782	454
	> 150 °C / 302 °F ≤ 200 °C / 392 °F	813	533

* all data in mbar (absolute)

Note:
Properties/applications shown throughout this brochure are typical. Your specific application should not be undertaken without independent study and evaluation for suitability. For specific application recommendations consult Garlock. Failure to select the proper sealing products could result in property damage and/or serious personal injury. Performance data published in this brochure has been developed from field testing, customer field reports and/or in-house testing. While the utmost care has been used in compiling this brochure, we assume no responsibility for errors. Specifications subject to change without notice. This edition cancels all previous issues. Subject to change without notice GARLOCK is a registered trademark for packings, seals, gaskets, and other products of Garlock. © Garlock Inc 2020. All rights reserved worldwide.

GARLOCK GMBH

an EnPro Industries family of companies

Falkenweg 1, 41468 Neuss, Germany

Tel: +49 2131 349 0

www.garlock.com

Garlock Sealing Technologies

GPT

Garlock PTY

Garlock India Private Limited

Garlock de Canada, LTD

Garlock China

Garlock Singapore

Garlock USA

Garlock de Mexico, S.A. De C.V.

Garlock New Zealand

Garlock Great Britain Limited

Garlock Middle East